

MODEL	TORQUE [Nm]	OPENING/ CLOSING TIME	POWER SUPPLY	COMMAND	IP GRADE
MVS216	16	60 s	230 Vac	2p	IP65
MVS416	16	60 s	24 Vac	2p	IP65
MVS516	16	60 s	24 Vac/dc	0..10 V	IP65

APPLICATION AND USE

The actuator MVSx16 is used on ball valve installed on the heating or conditioning systems for hot or cool water.

For control applications with ball valves modulating of VSC-VDC series is available a version of MVS with proportional command 0..10 V.

OPERATION

The actuators are without spring return. At the decrease of the ambient temperature the controller with on-off output closes the control contact of the actuator by opening the valve. When it reaches the required temperature, the controller open the contact, closing the valve.

The end of stroke contact closes at fully open valve and opens as soon as the valve starts closing.

End of stroke contact:

Close = Open valve
Open = close valve

For the MVS516 version with proportional control 0..10 V the valve position can be adjusted seamlessly from completely closed valve (command 0 V) to fully open valve (10 V command) depending on the control requirements.

Handle for manual control state of opening/closing, with LED indication.

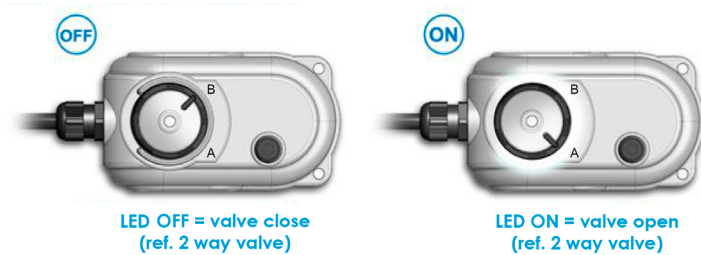

ACTUATOR	CONTROL			
	OFF*	ON	0 Vdc*	10 Vdc
MVS216 MVS416	position B	position A	-	-
MVS516	-	-	position A	position B

* factory position without power supply

Controlli S.p.A.
16010 Sant'Olcese (GE)
Tel. 010 73 06 1
Fax. 010 73 06 870/871
www.controlli.eu



POSSIBLE CONNECTIONS AND MATCHES

ACTUATORS	BALL VALVES	
MVS216 MVS416	2 way	VSS6, VSS8
	3 way diverting	VSD5, VSD6, VSD8
MVS216 MVS416 MVS516	2 way modulating	VSC2, VSC3, VSC4, VSC5, VSC6, VSC8
	3 way modulating	VDC2, VDC3, VDC4, VDC5, VDC6, VDC8

They are supplied with two coupling flanges for connections ISO 5211 F03/F05 or F04 to be used depending on the valve that is intended to motorize.

FLANGES	SHAFT	BALL VALVES
F03 F05	Q11	series VSS 1 1/2" - 2" series VSD 1 1/4" - 2"
F04	Q9	series VSC series VDC

MANUFACTURING CHARACTERISTICS

The actuator is equipped with manual control for opening the valve in case of lack of power supply.

The following figure shows how it works on the manual command:

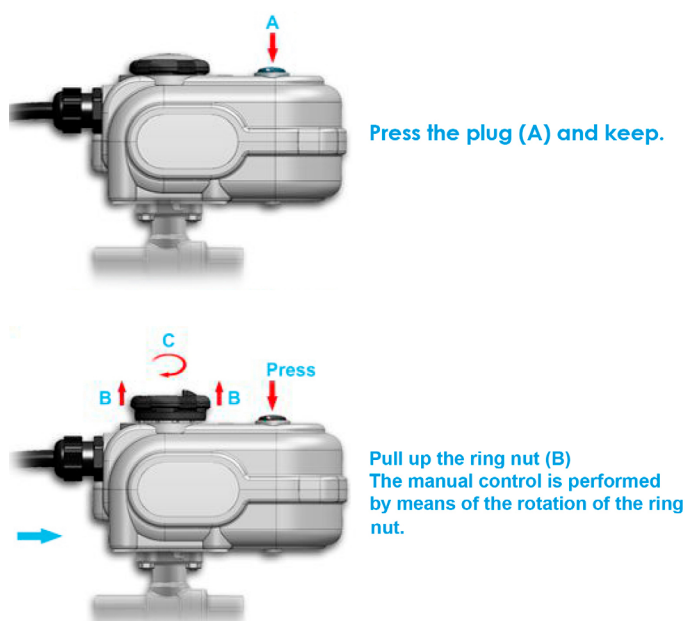

The lowered ring allows the reduction of the overall dimensions of the actuator. Once extracted facilitates the rotation thanks to a larger area of grip.

CONDENSATION HEATER

The anti-condensate resistance if connected is always active, both with open or close valve.

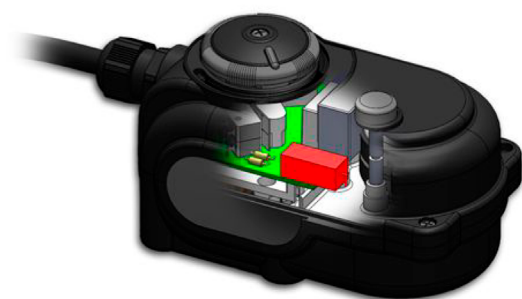

Use:

- ambient temperature <math>< 10^{\circ}</math>
- In addition to the thermal spacer with ambient temperature $30^{\circ}\text{C} \div 45^{\circ}\text{C}$ and the fluid temperature $< 15^{\circ}\text{C}$ (cool water).

We recommend the use of ambient temperature heating applications next to the limit.

ACCESSORIES

It is available a spacer MVSHT for use in case of cool water to allow a smoother insulation or in case of hot water with temperature higher than 120°C .

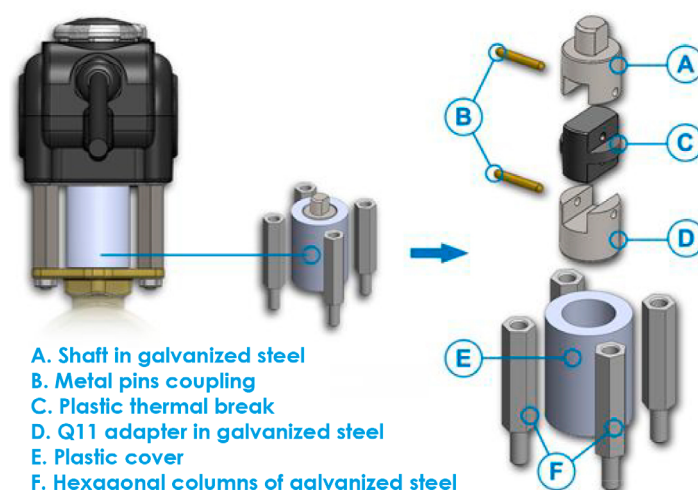

TECHNICAL CHARACTERISTICS

	230 Vac (MVS216)
Power supply:	24 Vac (MVS416 e MVS516)
	24 Vdc (MVS516)
Torque:	16 Nm
Temp. on work:	$-5^{\circ}\text{C} \div 50^{\circ}\text{C}$
Stock temp.	$-10^{\circ}\text{C} \div 80^{\circ}\text{C}$
Max umidity:	95%
IP grade:	IP65
Certification:	CE
Dimension:	135(156 with cable gland)x75x80 mm
Control:	0.. 10 V (MVS516)
	manual open/close with LED indicator (MVS416 and MVS216)
Feedback:	0.. 10 V (only MVS516)
Micro Aux:	230 Vac - 6 (1) A (only MVS416 and MVS216)
Insulation class:	II
Stroke time (open/close)	60 s
Flange:	ISO 5211 F03-F05 and ISO 5211 F04
Shaft:	Q11
Cable:	H05 6 poli x 0,75
Cable gland:	PG11 - IP68 ripstop
Weight:	0,90 Kg

POWER CONSUMPTION [VA]





MODEL	RUNNING	CLOSING POSITION	OPENING POSITION
MVS216	~6	0*	~1
MVS416	~6	0*	0,5*
MVS516	~5	~1	~1

* +1 VA if anti-condensation is connected

ASSEMBLING

For a correct assembly of the MVSx16 actuator to the valve:

- Choose the correct coupling flange supplied (table page 1), place it on the actuator and tighten the screws supplied
- Before coupling the valve to the actuator, check the positions shown in the table:

VALVES	VALVE STEM	MVS216 MVS416	MVS516
VSC2, VSC3, VSC4, VSC5, VSC6, VSC8	 open valve	position A	position B
VSS6 VSS8	 open valve	position A	position B
VDC2, VDC3, VDC4, VDC5, VDC6, VDC8	 open valve	position A	position B
VSD5 VSD6 VSD8	 open A - B	-	position A

- Couple the valve with actuator using nuts and bolts supplied
- Make the electric connections as shown in the wiring diagram
- With the actuator supplied, without control signal, the following condition is present:

VALVES	VALVE POSITION
VSC2, VSC3, VSC4, VSC5, VSC6, VSC8	valve closed
VSS6 VSS8	valve closed
VDC2, VDC3, VDC4, VDC5, VDC6, VDC8	3-way A - AB closed
VSD5 VSD6 VSD8	3-way A - B open

Any mounting position is allowed except the one with the actuator facing down.



Positions allowed

ELECTRIC CONNECTIONS

The actuator is complete with a 6 wires connection cable (5 + Resistance), with PG11 cable gland and auxiliary limit contact.

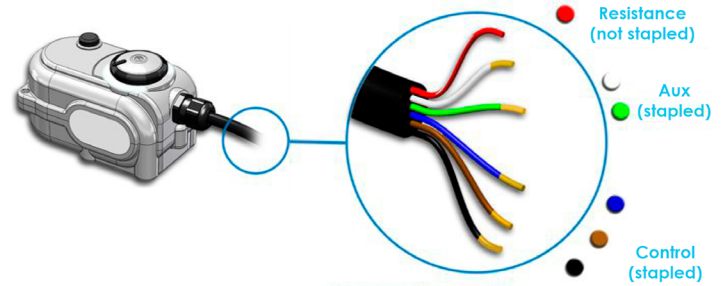

WHITE-GREEN-BLUE-BROWN-BLACK = control and auxiliary cables
RED = cable resistance

Modulating control 0..10 V 24 Vac (model MVS516)

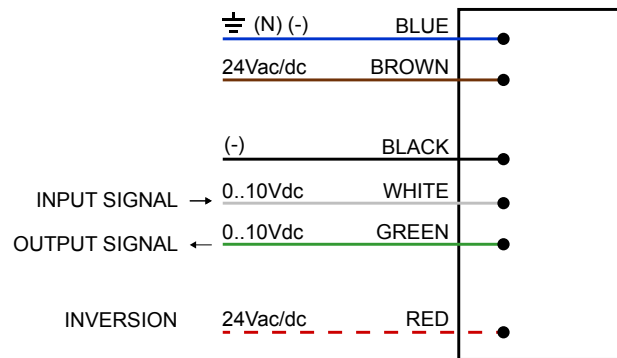

N.B.: "neutral" of the power supply refers to "earth".

! ATTENTION

MVS516 is built with a dual half-wave power stage so it can not be used with other devices with single half-wave power stage that share the same power supply and the same control signal reference. In this case it is necessary to use an isolation transformer. It is possible to share the same power supply but in this case **NOT CONNECT** the BLACK wire so as not to damage the device as shown in the following example:

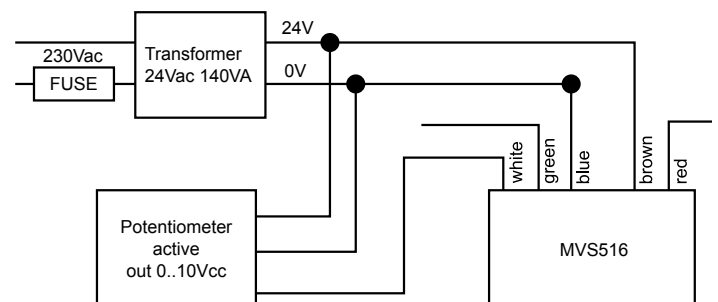

To reverse the action sense connect the red wire to 24 Vac/dc phase. At the first switch-on, after a learning cycle, the actuator is positioned with respect to the signal.

ON-OFF control (model MVS216, MVS416)

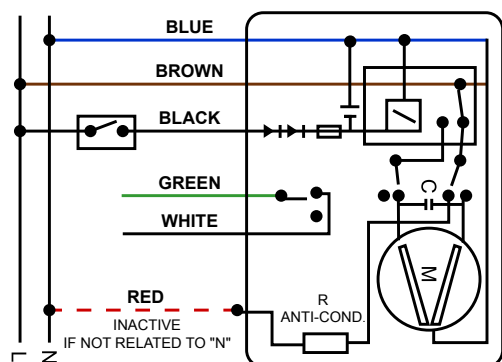

DIMENSIONS [mm]

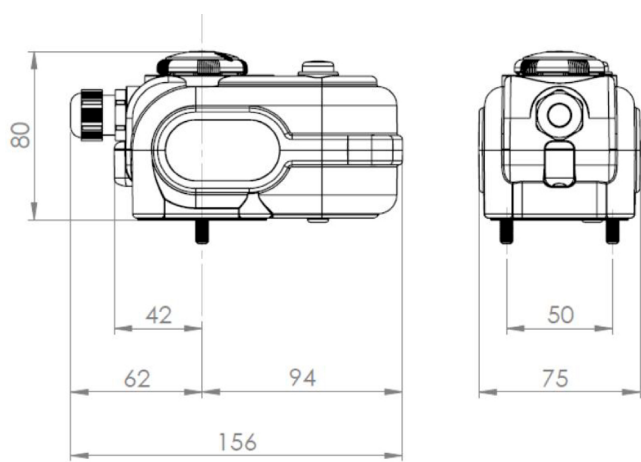

The performances stated in this sheet can be modified without any prior notice