

Gas monitor

Belimo gas monitors are factory calibrated and can monitor up to two gases simultaneously. All monitors feature audible and visual alarms, and CAN bus communication, allowing for standalone operation and networking of up to 32 devices. Select models feature relays and analog outputs to control ventilation directly, as well as BACnet MS/TP allowing for integration into a BMS. All gas monitors are wired via a daisy chain and are backed by a five-year warranty.



5-year warranty



Gas Monitor

Type Overview

| Type | Measured values | Number of relays | Number of analogue outputs | Communication |
|------------|---------------------|------------------|----------------------------|-----------------------|
| 22G0214-5A | CO, NO ₂ | 1 | 2 | CAN bus, BACnet MS/TP |
| 22G0214-5B | CO, NO ₂ | 2 | 0 | CAN bus, BACnet MS/TP |
| 22G0214-5C | CO, NO ₂ | 0 | 0 | CAN bus |

Technical data

| | Electrical data | |
|--|---------------------------|---|
| | Nominal voltage | AC/DC 24 V |
| | Nominal voltage note | Please see remarks section for nominal voltage details and nominal voltage range. |
| | Nominal voltage frequency | 50/60 Hz |
| | Power consumption AC | 5 VA |
| | Power consumption DC | 1.7 W |
| | Cable entry | 2 top, 2 bottom, 1 rear – 1/2" EMT |
| | Cable specification | Power cable: 18...20 AWG Communication cable: 22...24 AWG twisted pair, shielded jacketed, low capacitance Please see the remarks section for more information about cable size and polarity. |
| | Fuse | Thermal PTC, auto-reset |
| | Data bus communication | Communication |
| | | CAN bus BACnet MS/TP |

| | | |
|--------------------------|----------------------------------|--|
| Functional data | Application | Air |
| | Output signal active note | Analog outputs: 2...10 V or 4...20 mA, user selectable with jumper |
| | Output signal relay note | Relays: SPDT, 5A @ AC 125 V, non-inductive Please see remarks section for relay rating. |
| | Mounting | Please see installation notes section for mounting height recommendations. |
| | Max. altitude | 2000 m [6562 ft] above sea level |
| | Max. altitude note | Calibration verification is recommended above 610 m [2000 ft] |
| | Coverage area | Radius: 15 m [50 ft] Area: 700 m ² [7500 ft ²] There can be no obstructions such as walls, elevators, stairs, shelving with solid fill, tool chests, etc. Otherwise the time weighted average (TWA) for the gas to reach the monitor will increase. |
| | Display | LCD with backlight showing gas type, gas concentration, alarm level status |
| | Alarm | Alarm level 1: Visual alarm (red LED) Alarm level 2: Visual alarm (red LED) Alarm level 3: Visual and audible alarm (flashing white strobe LED and horn) Horn: 80 dB @ 1 m [3.3ft] |
| | Warm-up time | 5 minutes |
| Measuring data | Measured values | CO NO ₂ |
| Specification Gas | Sensing element technology | Electro-chemical |
| | Measuring range | CO: 0...250 ppm NO ₂ : 0...10 ppm |
| | Accuracy | CO: ±3% FS from 0...75 ppm @ 23.5°C [74°F] NO ₂ : -0.1...6.5% FS from 0...2 ppm @ 23.5°C [74°F] FS: Full scale of the measuring range Please see the remarks section for more information about the accuracy for CO and NO ₂ sensors. |
| | Measurement repeatability | <+3% CO equivalent <+2% NO ₂ equivalent |
| | Long term stability | CO: <5% per year NO ₂ : <2% per month |
| | Calibration | Non-interactive zero and span Sensor modules are required to be calibrated annually. |
| | Typical response time | <30 s (T90) |
| | Specification Temperature | Measuring range |

Technical data

| | | |
|----------------------------------|------------------------------|---|
| Specification Temperature | Accuracy temperature passive | ±7°C @ 23.5°C [13°F @ 74°F] Please see remarks section under application notice for more information about temperature accuracy |
| Safety data | Degree of protection IEC/EN | IP44 |
| | Degree of protection NEMA/UL | NEMA 2 |
| | Agency Listing | cULus listed to UL2075, ULC-S588 cCSAus listed to C22.2 No. 61010-1-12, UL Std. No. 61010-1 (3rd Edition), harmonized under IEC/EN 61010-1 BTL listed No. BTL-30001 |
| | Pollution degree | 2 |
| | Ambient humidity | 15...90% RH continuous, 0...99% RH intermittent, non-condensing |
| | Ambient temperature | -20...40°C [-4...104°F] |
| Materials | Housing | UL94 5VA |

Remarks

| | |
|--|---|
| Nominal voltage details | All Belimo gas monitors, communication modules, and relay units can be powered by AC/DC 24 V. Under CSA/UL 61010-1 all gas monitors and communication modules are rated to AC 24 V only. Under ULC-S588 and UL 2075 all vehicle emissions gas monitors (CO, NO ₂ , CO + NO ₂) are rated to AC/DC 24 V. |
| Nominal voltage range | All Belimo gas monitors, communication modules, and relay units have a nominal voltage range of AC 17...28/DC 21...38 V (not UL or CSA tested), AC/DC 20.4...26.4 V (UL tested). |
| Power cable size and polarity | Terminal blocks can accommodate one 14...20 AWG wire, or two 18...20 AWG wires in the same terminal. Please consider cable and transformer size to provide adequate voltage. For all power (AC/DC 24 V) maintain the same polarity between devices. |
| Communication cable size and polarity | CAN bus and BACnet MS/TP communication cables should be 22...24 AWG, twisted pair, shielded jacketed, low capacitance. Please consider CAN bus baud rate (programmable setting No. 68) and BACnet MS/TP baud rate (programmable setting No. 48) to provide working communication. For all communication wiring, maintain the same polarity and baud rate between all devices on the network. |
| Relay rating | All relays used in Belimo gas monitors, communication modules, and relay units are rated for: SPDT, 5 A @ AC 125 V, non-inductive (UL/CSA tested), SPDT, 5 A @ AC 240 V, non-inductive, (not UL/CSA tested), and SPDT, 4 A @ DC 24 V, non-inductive (not UL/CSA tested). |
| Application notice for temperature sensor | All Belimo gas monitors and communication modules come with an internal temperature sensor. The purpose of this temperature sensor is to protect an enclosed parking garage from overheating or freezing, by activating relay 1. When using this feature, it is recommended to calibrate the temperature sensor to the ambient temperature (programmable setting No. 50), after the gas monitor has been powered for 24 hours. For freeze protection, it is recommended to set the temperature set point (programmable settings No. 55) at or over 40°F [4°C]. Please note that this temperature sensor is located on the gas monitor printed circuit board (PCB). Therefore, it needs to be calibrated after 24 hours of normal operation to offset the heat generated by the PCB. It is not intended to be used as a room temperature sensor because of its limited accuracy and slow response time due to its location on the PCB. This temperature sensor accuracy of ±13°F @ 74°F [7°C @ 23.5°C] was not certified by UL. |
| Accuracy for gas monitors | CO and NO ₂ sensor accuracies are not certified by UL. Both accuracies were internally tested and validated in an environmental chamber and compared to a high accuracy reference device (analyzer). |

Installation notes
Mounting height recommendations

CO mounting height recommendations in an enclosed parking garage are the same regardless of the types of vehicles being stored and the height of the parking garage.

NO₂ mounting height recommendations in an enclosed parking garage are dependent on the types of vehicles being stored and the height of the parking garage.

If a parking garage is taller than 4.5 m [15 ft], it is a good indicator that larger vehicles like trucks and heavy equipment will be stored there. Because a majority of larger vehicles have diesel engines, which release NO₂ as a byproduct, and have their exhaust released from above the vehicle, we recommend NO₂ monitors to be mounted at half of the ceiling height, and/or above the diesel exhaust, and CO monitors to be mounted at 0.9...2.1 m [3...7 ft] from the floor. The ideal location for CO is 1.5 m [5 ft].

When the monitor is mounted at the correct height, it is less likely to be damaged by passing cars and trucks, and it is in a good location to be serviced. For these applications we offer a high low kit (A-22G-A14) that allows the installer to place the gas monitor at 0.9...2.1 m [3...7 ft] from the floor to monitor CO, and place the high low kit at half of the ceiling height and above the diesel exhaust, to remotely monitor NO₂. An RJ45 cable runs from the gas monitor to the high low kit to connect the two.

If a parking garage is lower than 4.5 m [15 ft], it is a good indicator that larger vehicles will not be stored here. In these applications we recommend that CO and NO₂ be monitored at 0.9...2.1 m [3...7 ft] from the floor. Again, the ideal location is 1.5 m [5 ft]. In these applications we recommend that CO and NO₂ can be monitored at the same height.

Accessories

| Replacement sensor modules | Description | Type |
|----------------------------|--|------------|
| | Sensor module CO (Carbon Monoxide), 0...250 ppm, | R-G02 |
| | Sensor module NO ₂ (Nitrogen Dioxide), 0...10 ppm, | R-G14 |
| Electrical accessories | Description | Type |
| | Communication module, CAN bus, BACnet MS/TP, 1 relay, 2 analog outputs | C-22G-5A |
| | Communication module, CAN bus, BACnet MS/TP, 2 relays | C-22G-5B |
| | Communication module, CAN bus | C-22G-5C |
| | Relay unit, CAN bus, 4 relays | C-22G-50 |
| | High-low mounting kit | A-22G-A14 |
| | External visual alarm | A-22G-A15 |
| | External audible alarm | A-22G-A16 |
| | Transformer, 50 VA | A-22G-A50 |
| | Transformer, 100 VA | A-22G-A100 |
| Mechanical accessories | Description | Type |
| | Splash proof enclosure | A-22G-A12 |
| | Duct mount enclosure | A-22G-A13 |
| | Calibration kit, | A-22G-A22 |

Wiring diagram

22G..-5A / C-22G-5A

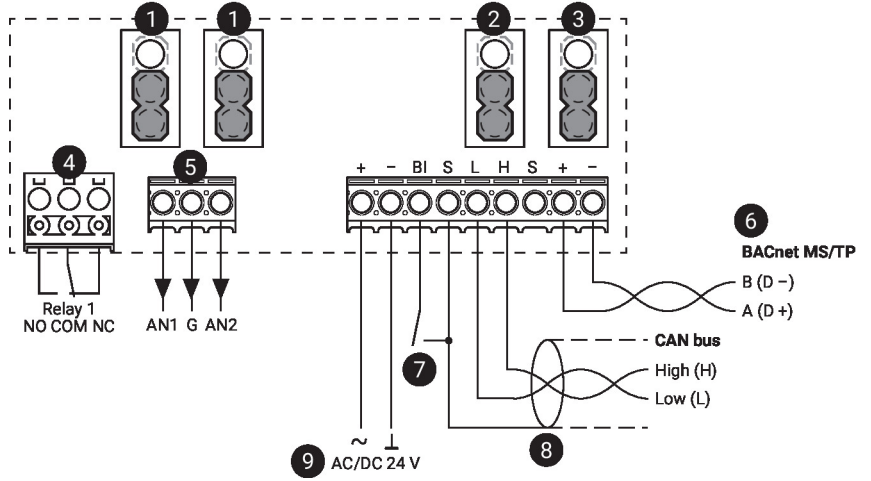

22G..-5B / C-22G-5B

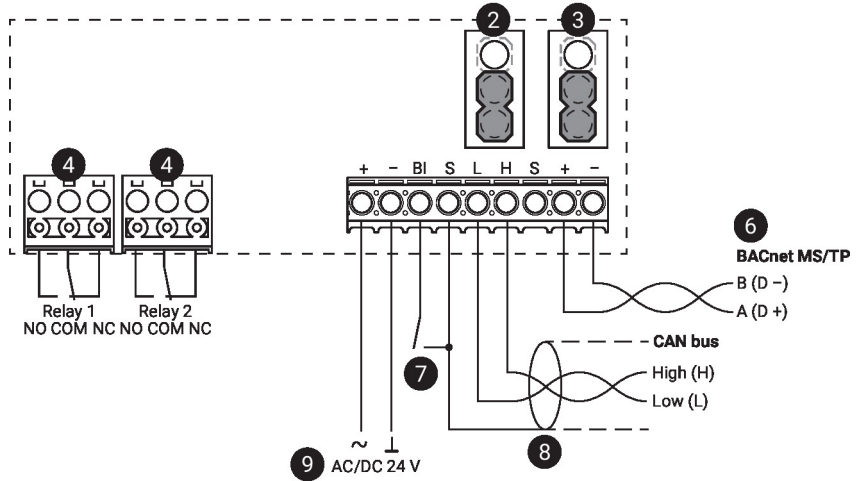

22G..-5C / C-22G-5C

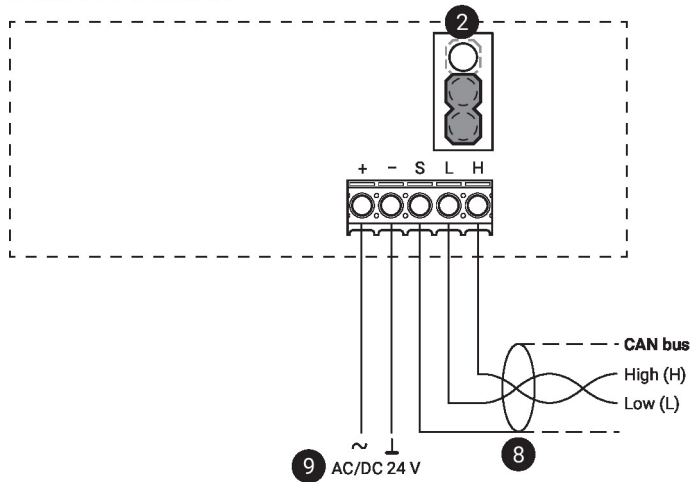

- 1 Analog outputs**
 Down position: 2....10 V (factory setting)
 Up position: 4...20 mA
- 2 End of line (EOL) jumper: CAN bus**
 Down position: Termination OFF (factory setting)
 Up position: Termination ON (first and last unit only should have this jumper in the up position)
- 3 End of line (EOL) jumper: MS/TP**
 Down position: Termination OFF (factory setting)
 Up position: Termination ON (first and last unit only should have this jumper in the up position)
- 4 Relay output**
- 5 Analog output**
- 6 Shield connected at the first unit only, at others only looped through**
- 7 Binary input to limit switch**
- 8 Shield connected at the first unit only, at others only looped through**
- 9 Binary input to limit switch**

Wiring CAN bus

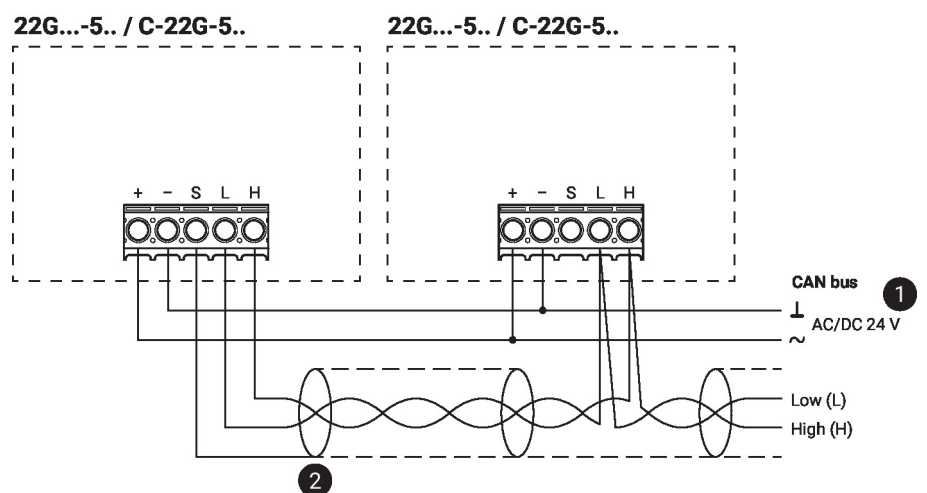

- 1** No connection to the ground
- 2** Shield connected at the first unit only, at others only looped through

Wiring diagram

Wiring RS-485 BACnet MS/TP

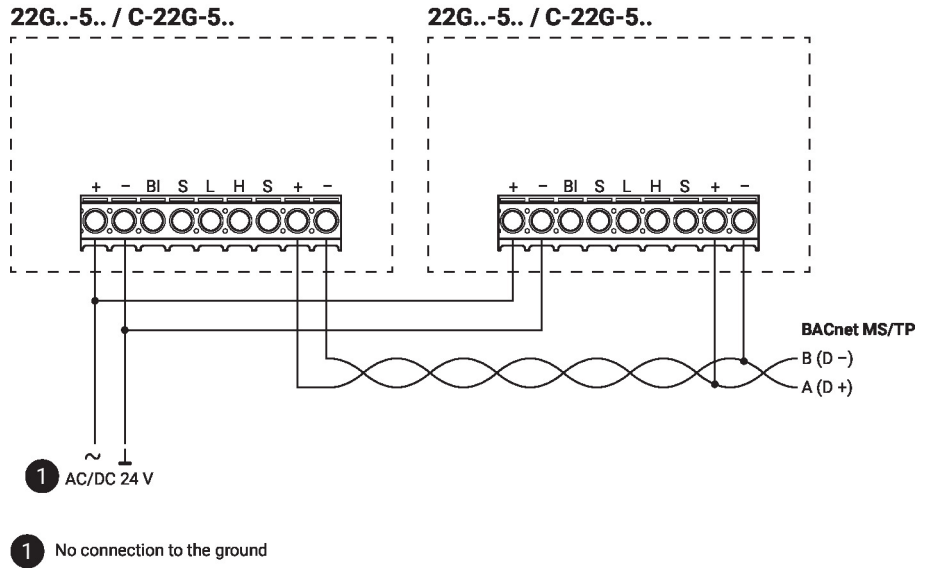

Dimensions

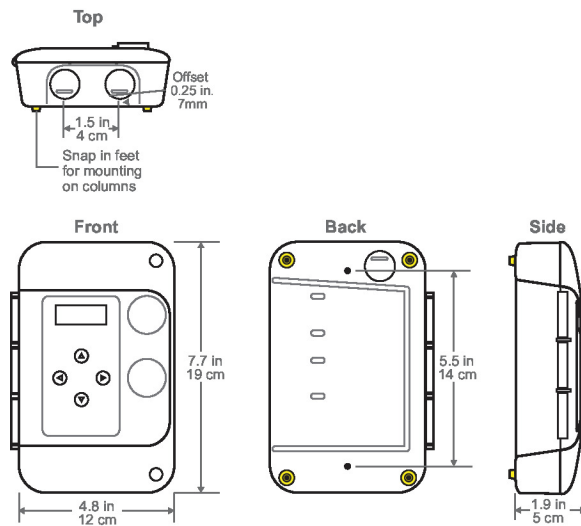

Type

- 22G0214-5A
- 22G0214-5B
- 22G0214-5C

Weight

- 0.45 kg
- 0.45 kg
- 0.45 kg

Further documentation

- Installation instructions
- Operating instructions