

Thermal energy meter

Thermal energy meter for measuring energy in a closed heating or cooling circuit. It is equipped with automatic glycol compensation and automatically and continuously measures the glycol content in the medium and compensates it, thus ensuring reliable measurement of the thermal energy. If required, the power supply can be provided via PoE (Power over Ethernet). Communication is provided via BACnet, Modbus, MP-Bus or M-Bus (with Converter). Parametrisation is done with the Belimo Assistant App via NFC technology or via web server. The commissioning report can be generated automatically. Connection to the Belimo Cloud is possible.

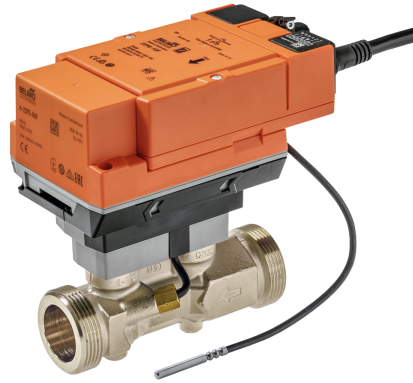

Type Overview

Type	DN	G ["]	qp [m ³ /h]	qs [m ³ /h]	qi [m ³ /h]	Δp [kPa]	Q'max [kW]	PN
22PE-1UHH	50	2 1/2	22.7	30	0.15	22	3500	25

qp = Nominal flow

qs = Highest flow

qi = Lowest flow

kvs theor.: Theoretical kvs value for pressure drop calculation

Δp = Pressure drop at nominal flow qp

Q'max = Maximum thermal output (q = qs, Δθ = 100 K)

Structure

Components The thermal energy meter consists of a sensor module with connected temperature sensors, which houses the calculator unit and measuring system, and the logic module, which connects the thermal energy meter to the power supply and provides the bus and NFC communication interface. The sensor module is available as a spare part.

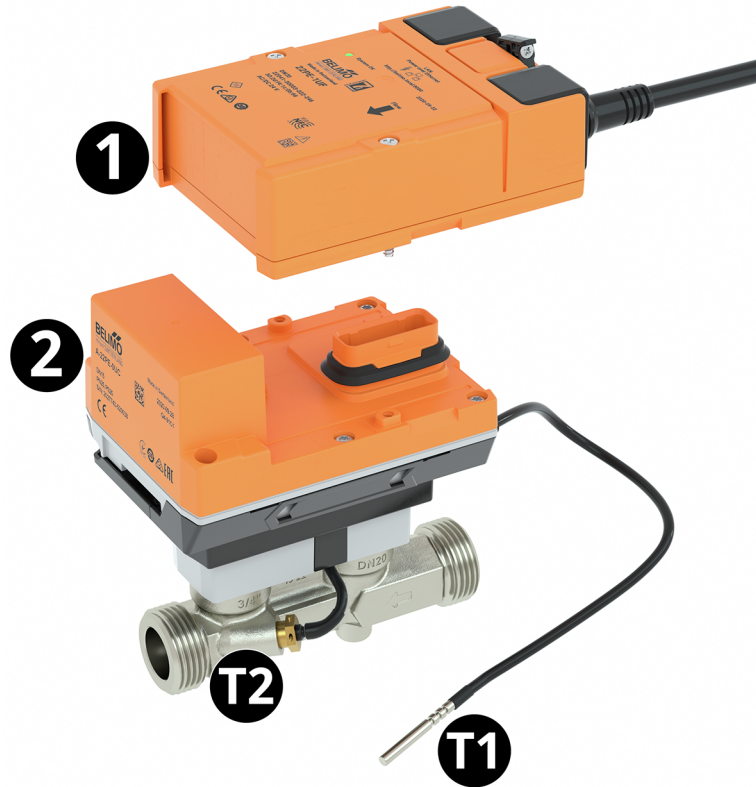

External temperature sensor T1
 Integrated temperature sensor T2
 Logic module 1
 Sensor module 2

Technical data

Electrical data	Nominal voltage	AC/DC 24 V
	Nominal voltage frequency	50/60 Hz
	Nominal voltage range	AC 19.2...28.8 V / DC 21.6...28.8 V
	Power consumption AC	3 VA
	Power consumption DC	1.5 W
	Power consumption PoE	2.2 W
	Connection supply	Cable 1 m, 6 x 0.75 mm ²
	Connection Ethernet	RJ45 socket
	Power over Ethernet PoE	DC 37...57 V IEEE 802.3af/at, Type 1, Class 3 11 W (PD13W)
	Conductors, cables	AC/DC 24 V, cable length <100 m, no shielding or twisting required Shielded cables are recommended for supply via PoE
Annual energy consumption	With external energy supply 13.2 kWh	
Data bus communication	Communication	BACnet/IP BACnet MS/TP Modbus TCP Modbus RTU MP-Bus

Technical data

Data bus communication	Communication note	M-Bus via Converter G-22PEM-A01	
	Number of nodes	BACnet / Modbus see interface description MP-Bus max. 8 (16)	
Functional data	Application	Water Water-glycol mixture	
	Parametrisation	via NFC, Belimo Assistant App via integrated web server	
	Voltage output	1 x 0...10 V, 0.5...10 V, 2...10 V	
	PN	25	
	Pipe connection	External thread according to ISO 228-1	
	Servicing	maintenance-free	
	Measuring data	Measured values	Flow Temperature
Measuring principle		Ultrasonic volumetric flow measurement	
Specification Flow	Dynamic range qi:qp	1:100	
	Measuring accuracy flow	±2% (of 20...100% qp) @ 20°C / glycol 0% vol.	
	Measuring accuracy flow note	EN 1434 Class 2 @ 15...120°C	
Specification Temperature	Temperature sensor	Pt1000 - EN 60751, 2-wire technology, inseparably connected Cable length external sensor T1: 3 m	
	Measuring accuracy absolute temperature	± 0.35°C @ 10°C (Pt1000 EN60751 Class B) ± 0.6°C @ 60°C (Pt1000 EN60751 Class B)	
	Measuring accuracy temperature difference	±0.22 K @ ΔT = 10 K ±0.32 K @ ΔT = 20 K	
Safety data	Protection class IEC/EN	III, Protective Extra-Low Voltage (PELV)	
	Degree of protection IEC/EN	IP54 Logic module: IP54 (with grommet A-22PEM-A04) Sensor module: IP65	
	Pressure equipment directive	CE according to 2014/68/EU	
	EMC	CE according to 2014/30/EU	
	Certification IEC/EN	IEC/EN 60730-1:11 and IEC/EN 60730-2-15:10	
	Quality Standard	ISO 9001	
	Type of action	Type 1	
	Rated impulse voltage supply	0.8 kV	
	Pollution degree	3	
	Ambient humidity	Max. 95% RH, non-condensing	
	Ambient temperature	-30...55°C [-22...130°F]	
	Fluid temperature	-20...120°C [-5...250°F] At a fluid temperature of <2°C [<36°F], frost protection must be guaranteed	
	Storage temperature	-40...80°C [-40...176°F]	
	Materials	Fluid wetted parts	Brass nickel-plated, Brass, Stainless steel, PEEK, EPDM

Safety notes



This device has been designed for use in stationary heating, ventilation and air-conditioning systems and must not be used outside the specified field of application, especially in aircraft or in any other airborne means of transport.

Outdoor applications: Only possible where (sea) water, snow, ice, sunlight or aggressive gases cannot interfere directly with the device and it can be guaranteed that the ambient conditions remain at all times within the thresholds according to the data sheet.

Only authorised specialists may carry out installation. All applicable legal or institutional installation regulations must be complied with during installation.

The device contains electrical and electronic components and must not be disposed of as household refuse. All locally valid regulations and requirements must be observed.

Product Features

Operating mode	<p>The thermal energy meter consists of a volume measuring part, evaluation electronics and two temperature sensors. One temperature sensor is integrated in flow sensor, the other temperature sensor is installed as an external sensor. The device determines the thermal energy supplied to consumers via a heating circuit or extracted from a heat exchanger via a cooling circuit from the volumetric flow and the temperature difference between supply and return flow.</p> <p>The thermal energy meter is designed as a multifunctional device and can be used as a heat meter, cooling meter or heat/cooling meter. In addition, it can be installed either in the return or in the supply of the system. The installation in the return or in the supply is selected during commissioning with a smartphone and the Belimo Assistant App.</p>
Calibration certificate	<p>A calibration certificate is available in the Belimo Cloud for each thermal energy meter. If required, this can be downloaded as a PDF with the Belimo Assistant App or via the Belimo Cloud frontend.</p>
Flow measurement	<p>The thermal energy meter measures the current flow rate every 0.1 s in mains operation.</p>
Power calculation	<p>The thermal energy meter calculates the current thermal power based on the current flow rate and the measured temperature difference.</p>
Invoicing energy consumption	<p>The energy consumption data can be read out as follows:</p> <ul style="list-style-type: none"> - Bus - Cloud API - Belimo Cloud Account of the device owner - Belimo Assistant App - Integrated web server
Belimo cloud	<p>The "Terms of Use for Belimo Cloud Services" in their currently valid version apply to the use of cloud services.</p> <p>Note: The connection to the Belimo Cloud is permanently available. Activation takes place via web server or Belimo Assistant App.</p>
PoE (Power over Ethernet)	<p>If necessary, the thermal energy meter can be supplied with power via the Ethernet cable. This function can be enabled via the Belimo Assistant App.</p> <p>DC 24 V (max. 8 W) is available at wires 1 and 2 for power supply of external devices (e.g. actuator or active sensor).</p> <p>Caution: PoE may only be enabled if an external device is connected to wires 1 and 2 or if wires 1 and 2 are insulated!</p>
Commissioning report	<p>Once commissioning has been completed, a commissioning report is available via the web server or the Belimo Assistant App, in which all settings and basic data are presented in a clear and structured manner. The commissioning report can be saved as a pdf file.</p>

Spare parts Sensor module of the thermal energy meter consisting of:
 - 1 x sensor module including integrated temperature sensor T2 and external temperature sensor T1

Pressure drop The pressure drop across the thermal energy meter to achieve a desired volumetric flow q can be calculated using the theoretical kvs value (see type overview) and the formula below.

Formula pressure drop

$$\Delta p = \left(\frac{q}{k_{vs\ theor.}} \right)^2 * 100 \ kPa$$

Δp : kPa
 q : m³/h
 $k_{vs\ theor.}$: m³/h

Example pressure drop calculation

22PE-1UE (DN 25)

$k_{vs\ theor.} = 13.2 \ m^3/h$

$q_p = 3.5 \ m^3/h$

$q = 1.7 \ m^3/h$

$$\Delta p = \left(\frac{q}{k_{vs\ theor.}} \right)^2 * 100 \ kPa = \left(\frac{1.7 \ m^3/h}{13.2 \ m^3/h} \right)^2 * 100 \ kPa = 1.66 \ kPa$$

Pressure drop diagram

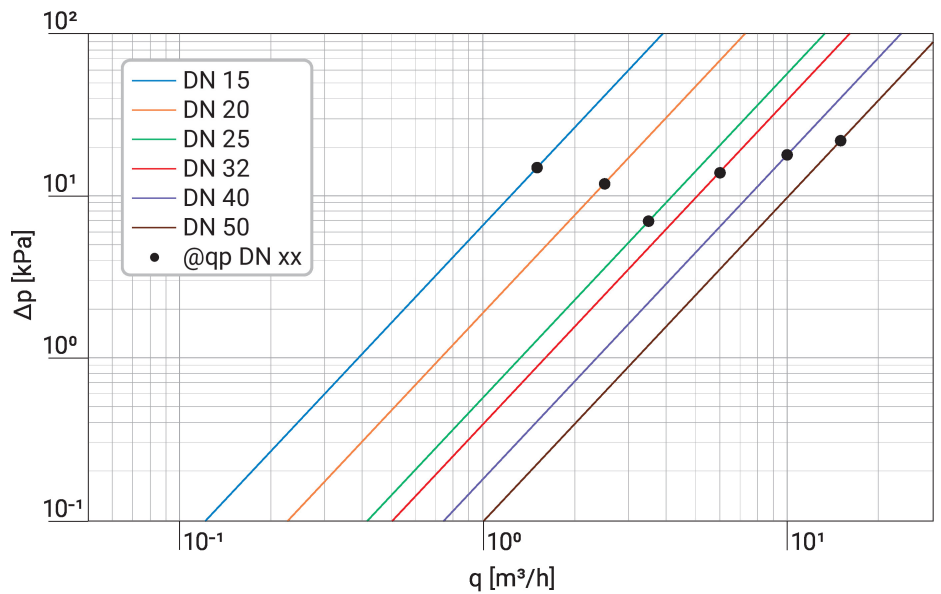

Δp = Pressure drop
 q = Measured flow

Product Features

Measuring accuracy Measuring accuracy for water (glycol 0% vol.):
 ±2% (@ 20...100% qp)
 At a temperature range of 15...120 °C.
 Measuring accuracy for water + glycol (glycol 0...60% vol.)
 ±5% (@ 20...100% qp) ±0.01 qp, but not more than 30% of q (@ qi...20% qp)
 At a temperature range of -20...120°C.

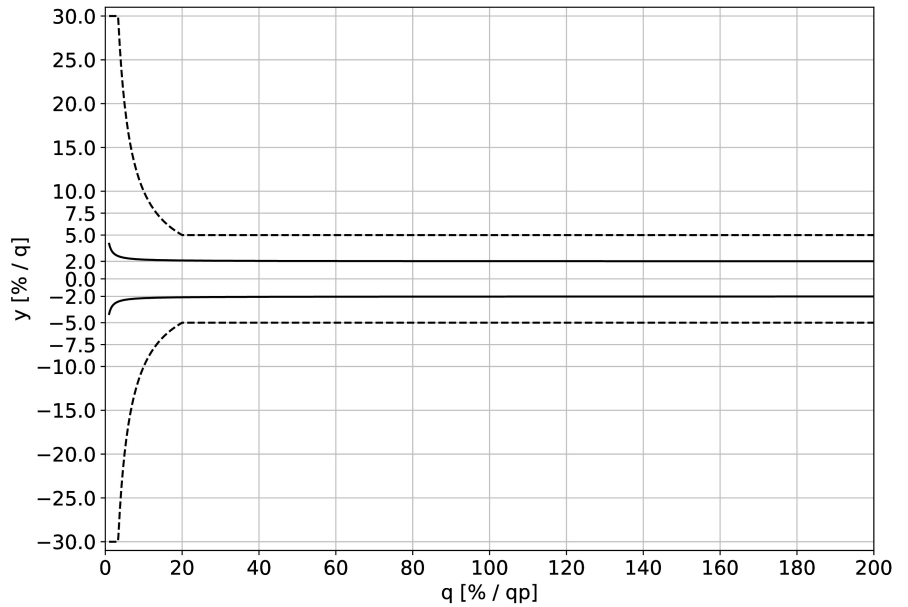

— Water
 ---- Water + Glycol (≤60% Glycol)
 y = Measuring accuracy
 q = Measured flow
 qp = Nominal flow

Indicators and Operation

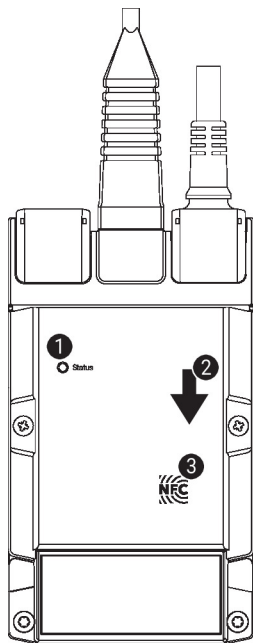

- ① **LED display green**
 On: Device starting up
 Flashing: In operation (Power ok)
 Off: No power
- ② **Flow direction**
- ③ **NFC interface**

Installation notes

Permissible installation orientation The sensor can be installed upright to horizontal. The sensor may not be installed in a hanging position.

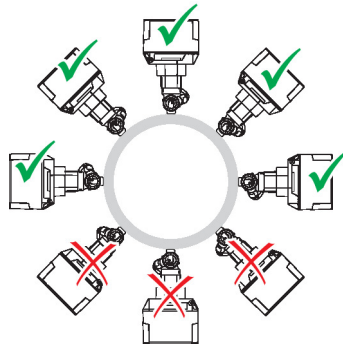

Installation in return Installation in the return is recommended.

Dimensioning The thermal energy meter is dimensioned to the nominal flow (qp). The flow rate may increase to the highest flow (qs) for a short time (<1h/day).

Inlet section In order to achieve the specified measuring accuracy, a flow-calming section or inflow section in the direction of the flow is to be provided upstream from the flow sensor. Its dimensions should be at least 5x DN.

- a) Recommended installation locations
- b) Prohibited installation location due to the danger of air accumulation
- c) Installation immediately after valves is prohibited. Exception: If it is a shut-off valve without constriction and it is 100% open
- d) Installation on the suction side of a pump is not recommended

DN	L min.
15	5 x 15 mm = 75 mm
20	5 x 20 mm = 100 mm
25	5 x 25 mm = 125 mm
32	5 x 32 mm = 160 mm
40	5 x 40 mm = 200 mm
50	5 x 50 mm = 250 mm

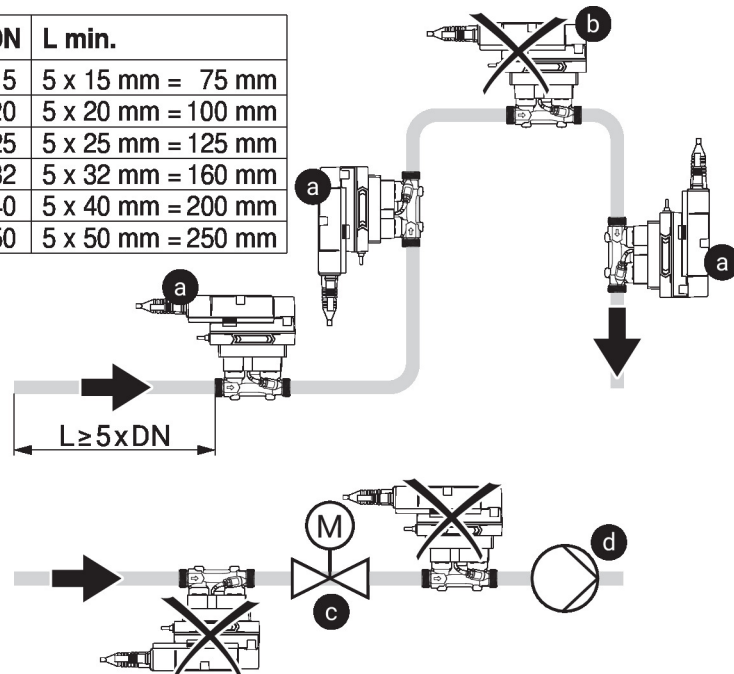

Water quality requirements The water quality requirements specified in VDI 2035 must be adhered to.

Installation notes

Servicing	<p>Thermal energy meter are maintenance-free.</p> <p>Before any service work on the thermal energy meter is carried out, it is essential to isolate the thermal energy meter from the power supply (by unplugging the electrical cables if necessary). Any pumps in the part of the piping system concerned must also be switched off and the appropriate slide valves closed (allow all components to cool down first if necessary and always reduce the system pressure to ambient pressure level).</p> <p>The system must not be returned to service until the thermal energy meter has been correctly reassembled in accordance with the instructions and the pipeline has been refilled by professionally trained personnel.</p>
Flow direction	<p>The direction of flow, specified by an arrow on the housing, is to be complied with, since otherwise the flow rate will be measured incorrectly.</p>
Avoiding cavitation	<p>To avoid cavitation, the system pressure at the outlet of the thermal energy meter must be a minimum of 1.0 bar at q_s (highest flow) and temperatures up to 90°C.</p> <p>At a temperature of 120°C the system pressure at the outlet of the thermal energy meter must be at least 2.5 bar.</p>
Cleaning of pipes	<p>Before installing the thermal energy meter, the circuit must be thoroughly rinsed to remove impurities.</p>
Prevention of stresses	<p>The thermal energy meter must not be subjected to excessive stress caused by pipes or fittings.</p>

Parts included

Description	Type
Grommet for RJ connection module with clamp	A-22PEM-A04
Thermowell Stainless steel, 50 mm, G 1/4", SW17	A-22PE-A07
Insulation shell for thermal energy meter DN 32...50	A-22PEM-A02
Insulation shell not included in Asia Pacific	

Accessories

Replacement sensor modules	Description	Type
	Sensor module thermal energy meter DN 50	R-22PE-0UH
Optional accessories	Description	Type
	Converter M-Bus	G-22PEM-A01
	Thermowell Stainless steel, 80 mm, G 1/2", SW27	A-22PE-A08
	Insulation shell for thermal energy meter DN 32...50	A-22PEM-A02
	T-piece with thermowell DN 50	A-22PE-A06
	Pipe connector DN 50 Rp 2", Set of 2 pcs.	EXT-EF-50D
Tools	Description	Type
	Belimo Assistant App, Smartphone app for easy commissioning, parametrising and maintenance	Belimo Assistant App
	Converter Bluetooth / NFC	ZIP-BT-NFC

Wiring diagram



Supply from isolating transformer.

The wiring of the line for BACnet MS/TP / Modbus RTU is to be carried out in accordance with applicable RS-485 regulations.

Modbus / BACnet: Supply and communication are not galvanically isolated. Connect earth signal of the devices with one another.

Sensor connection: An additional sensor can optionally be connected to the thermal energy meter. This can be a passive resistance sensor Pt1000, Ni1000, NTC10k (10k2), an active sensor with output DC 0...10 V or a switching contact. Thus the analogue signal of the sensor can be easily digitised with the thermal energy meter and transferred to the corresponding bus system.

Analogue output: An analogue output (wire 5) is available on the thermal energy meter. It can be selected as DC 0...10 V, DC 0.5...10 V or DC 2...10 V. For example, the flow rate or the temperature of the temperature sensor T1/T2 can be output as an analogue value.

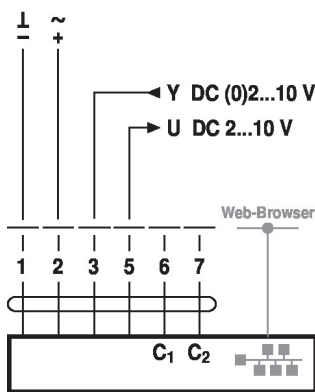

- Cable colours:
- 1 = black, GND
 - 2 = red, AC/DC 24 V
 - 3 = white, Sensor optional
 - 5 = orange, DC 0...10 V, MP-Bus
 - 6 = pink, C1 = D- = A
 - 7 = grey, C2 = D+ = B

BACnet IP / Modbus TCP

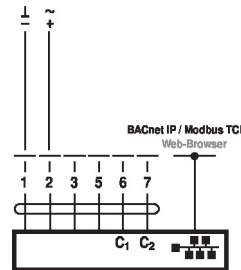

PoE with BACnet IP / Modbus TCP

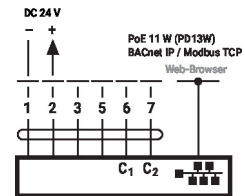

BACnet MS/TP / Modbus RTU

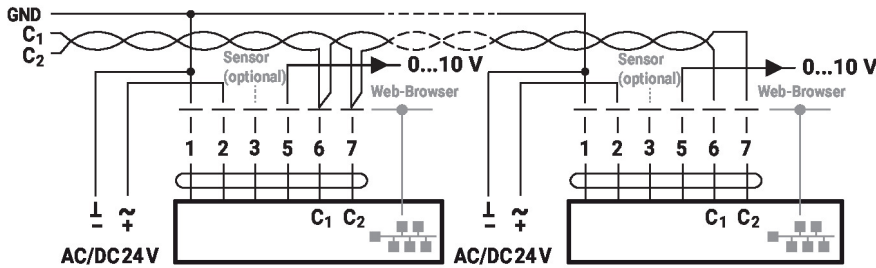

- C1 = D- = A
- C2 = D+ = B

MP-Bus, supply via 3-wire connection

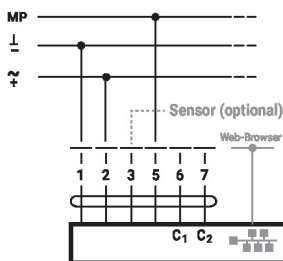

MP-Bus via 2-wire connection, local power supply

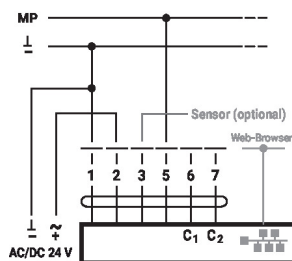

M-Bus via Converter M-Bus

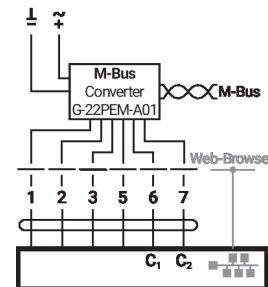

M-Bus parallel Modbus RTU or BACnet MS/TP

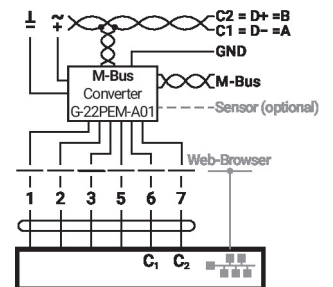

Wiring diagram

M-Bus parallel Modbus TCP or BACnet IP

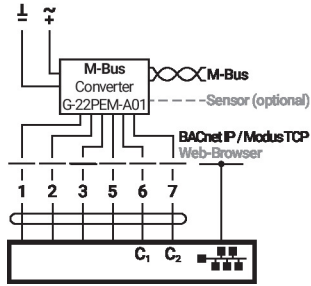

M-Bus parallel Modbus TCP or BACnet IP with PoE

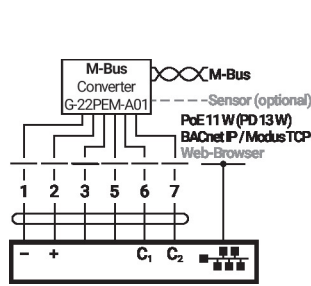

Connection with active sensor

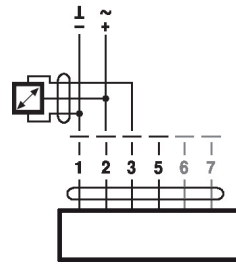

Connection with passive sensor

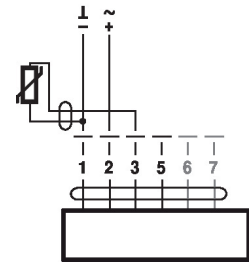

Connection with switching contact

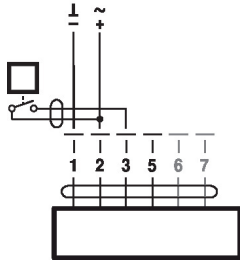

Dimensions

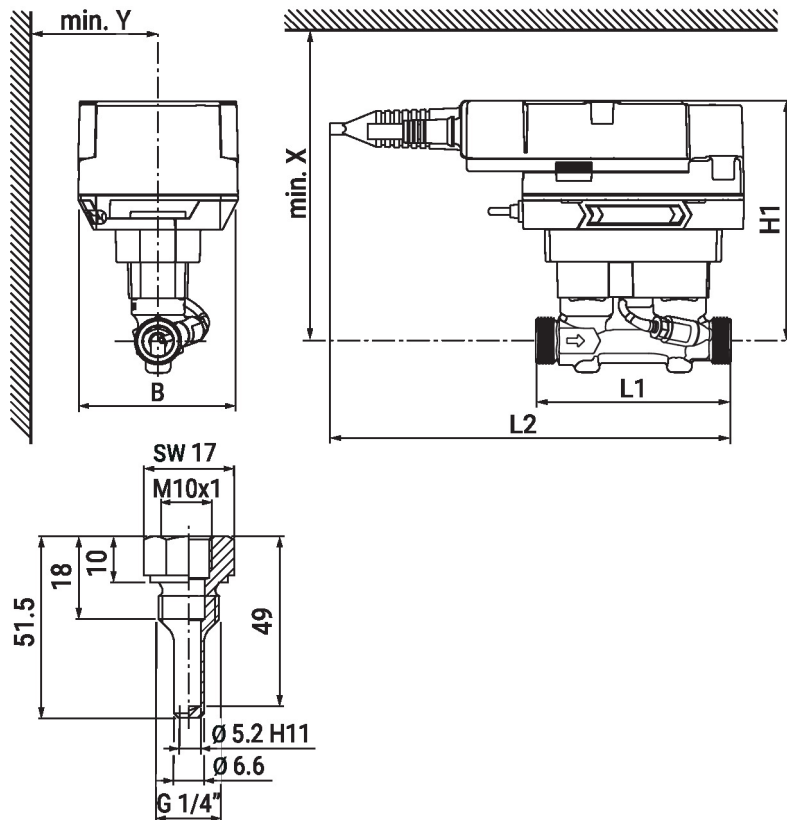

Thermowell for temperature sensor T1

Type	DN	L1 [mm]	L2 [mm]	B [mm]	H1 [mm]	X [mm]	Y [mm]	Weight
22PE-1UHH	50	145	230	90	152	222	85	2.5 kg

Further documentation

- Overview MP Cooperation Partners
- Description Data-Pool Values
- BACnet Interface description
- Modbus Interface description
- Installation instructions
- Operating instructions