

Outdoor sensor with weather shield Humidity / Temperature

For measuring the relative or absolute humidity and temperature in outdoor areas. Instead of the humidity signal, the enthalpy or the dewpoint can be selected as an output signal. IP65 / NEMA 4X rated enclosure.



Type Overview

Type	Output signal active humidity	Output signal passive temperature
22UTH-110M	0...5 V, 0...10 V	NTC10k Pre (10k3)

Technical data

Electrical data	Nominal voltage	AC/DC 24 V																			
	Nominal voltage range	AC 21.6...26.4 V / DC 13.5...26.4 V																			
	Power consumption AC	0.8 VA																			
	Power consumption DC	0.4 W																			
	Electrical connection	Pluggable spring loaded terminal block max. 2.5 mm ²																			
	Cable entry	Cable gland with strain relief ø6...8 mm																			
Functional data	Sensor technology	Polymer-based capacitive sensor with stainless steel wire mesh filter																			
	Application	Air																			
	Voltage output	1 x 0...5 V, 0...10 V, min. resistance 10 kΩ																			
	Output signal active note	Output 0...5/10 V with Jumper adjustable																			
Measuring data	Measured values	Relative humidity Absolute humidity Dew point Enthalpies Temperature																			
	Specification Temperature active	Measuring range temperature settings Active sensor: range selectable Attention: max. measuring temperature is restricted by max. fluid temperature (see Safety data) <table border="1"> <thead> <tr> <th>Setting</th> <th>Range [°C]</th> <th>Range [°F]</th> <th>Factory setting</th> </tr> </thead> <tbody> <tr> <td>S0</td> <td>-40...60</td> <td>-40...160</td> <td></td> </tr> <tr> <td>S1</td> <td>0...50</td> <td>40...140</td> <td></td> </tr> <tr> <td>S2</td> <td>-15...35</td> <td>0...100</td> <td></td> </tr> <tr> <td>S3</td> <td>-20...80</td> <td>0...200</td> <td style="text-align: right;">✓</td> </tr> </tbody> </table>	Setting	Range [°C]	Range [°F]	Factory setting	S0	-40...60	-40...160		S1	0...50	40...140		S2	-15...35	0...100		S3	-20...80	0...200
Setting	Range [°C]	Range [°F]	Factory setting																		
S0	-40...60	-40...160																			
S1	0...50	40...140																			
S2	-15...35	0...100																			
S3	-20...80	0...200	✓																		
	Time constant τ (63%) in the air duct	Typical 396 s																			
Specification Temperature passive	Measuring range	-35...50°C [-30...120°F]																			
	Accuracy temperature	±0.2°C @ 25°C [±0.35°F @ 77°F]																			
Specification Humidity	Measuring range	0...100% RH non-condensing																			
	Measuring range absolute humidity	adjustable at the transducer: 0...50 g/m ³ (default setting) 0...80 g/m ³																			

Technical data

Specification Humidity	Measuring range enthalpy	0...85 kJ/kg
	Measuring range dew point	adjustable at the transducer: 0...50°C (default setting) -20...80°C
	Accuracy	±2% between 0...80% RH @ 25°C
	Long term stability	±0.3% RH p.a. @ 21°C @ 50% RH
	Time constant τ (63%) in the air duct	Typical 16 s @ 0 m/s
Safety data	Protection class IEC/EN	III, Safety Extra-Low Voltage (SELV)
	Power source UL	Class 2 Supply
	Degree of protection IEC/EN	IP65
	Degree of protection NEMA/UL	NEMA 4X
	Enclosure	UL Enclosure Type 4X
	EU Conformity	CE Marking
	Certification IEC/EN	IEC/EN 60730-1
	Quality Standard	ISO 9001
	Type of action	Type 1
	Rated impulse voltage supply	0.8 kV
	Pollution degree	3
	Ambient humidity	Short-term condensation permitted
	Ambient temperature	-35...50°C [-30...122°F]
Fluid humidity	Short-term condensation permitted	
Fluid temperature	-35...50°C [-30...122°F]	
Materials	Cable gland	PA6, white
	Housing	Cover: PC, white Bottom: PC, white Seal: NBR70, black UV resistant

Safety notes

This device has been designed for use in stationary heating, ventilation and air-conditioning systems and must not be used outside the specified field of application. Unauthorised modifications are prohibited. The product must not be used in relation with any equipment that in case of a failure may threaten humans, animals or assets.

Ensure all power is disconnected before installing. Do not connect to live/operating equipment.

Only authorised specialists may carry out installation. All applicable legal or institutional installation regulations must be complied with during installation.

The device contains electrical and electronic components and must not be disposed of as household refuse. All locally valid regulations and requirements must be observed.

Remarks

General remarks concerning sensors When using lengthy connection wires (depending on the cross section used) the measuring result might be falsified due to a voltage drop at the common GND-wire (caused by the voltage current and the line resistance). In this case, 2 GND-wires must be wired to the sensor - one for supply voltage and one for the measuring current.

Sensing devices with a transducer should always be operated in the middle of the measuring range to avoid deviations at the measuring end points. The ambient temperature of transducer electronics should be kept constant. The transducers must be operated at a constant supply voltage (± 0.2 V). When switching the supply voltage on/off, onsite power surges must be avoided.

Remark: Occurring draft leads to a better carrying-off of dissipative power at the sensor. Thus temporally limited fluctuations might occur upon temperature measurement.

Build-up of self-heating by electrical dissipative power Temperature sensors with electronic components always have a dissipative power which affects the temperature measurement of the ambient air. The dissipation in active temperature sensors shows a linear increase with rising operating voltage. The dissipative power should be taken into account when measuring temperature.

In case of a fixed operating voltage (± 0.2 V), this is normally done by adding or reducing a constant offset value. As Belimo transducers work with a variable operating voltage, for reasons of production engineering only one operating voltage can be taken into consideration. Transducers 0...10 V / 4...20 mA have a standard setting at an operating voltage of DC 24 V. This means that at this voltage, the expected measuring error of the output signal will be the least. For other operating voltages, the offset error will be increased by a changing power loss of the sensor electronics.

If a readjustment directly at the active sensor should be necessary during later operation, this can be done with the following adjustment methods.

- For sensors with NFC or dongle with the corresponding Belimo app
- For sensors with a trimming potentiometer on the sensor board
- For bus sensors via bus interface with a corresponding software variable

Application notice for humidity sensors The humidity sensor is extremely sensitive. Touching the sensor element or exposing it to aggressive substances like chlorine, ozone, ammonia, hydrogen peroxide or ethanol (i.e. as a cleaning agent) may affect the measurement accuracy.

Long term operation outside the recommended conditions (5...60°C and 20...80% RH) can result in a temporary offset. After returning into the recommended range, this effect disappears.

Parts included

Description	Type
Mounting plate L housing	A-22D-A10
Rain cover, for 22UTH-..	A-22U-A01
Dowels	
Screws	

Accessories

Optional accessories	Description	Type
	Replacement filter sensor probe tip, wire mesh, Stainless steel	A-22D-A06

Wiring diagram

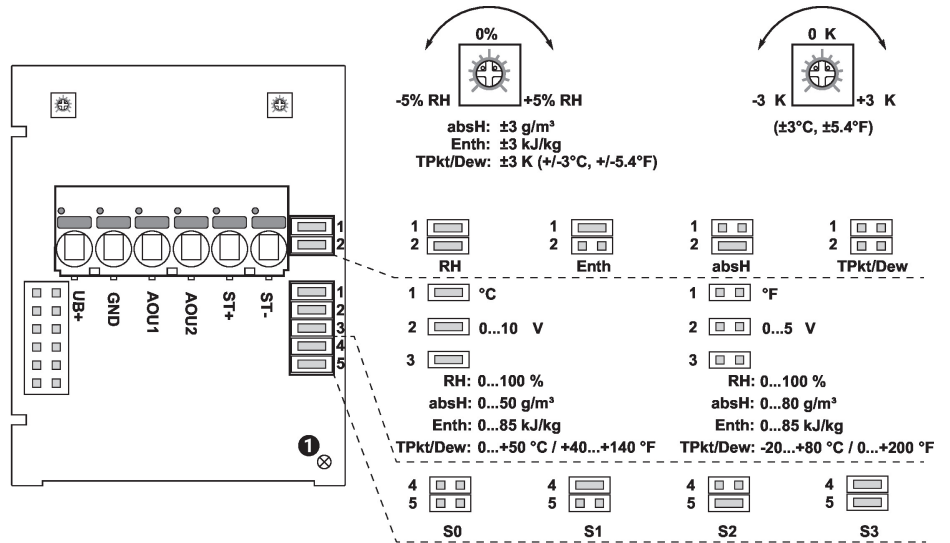

2 x 0...5/10 V + ST

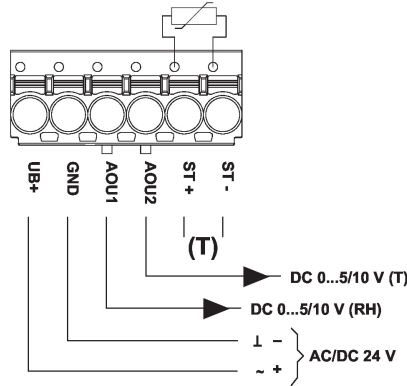

- ① Status LED
- RH Relative humidity
- absH Absolute humidity
- Enth Enthalpy
- TPkt/Dew Dew point
- (Measurement value available on Output AOU1)

Connectors ST+ / ST- are only used for sensor types which additionally have a passive resistance sensor element for temperature measurement.
The adjustment of the measuring ranges is made by changing the bonding jumpers.
The output value in the new measuring range is available after 2 seconds.

Setting	Range [°C]	Range [°F]	Factory setting
S0	-40...60	-40...160	
S1	0...50	40...140	
S2	-15...35	0...100	
S3	-20...80	0...200	✓

Dimensions

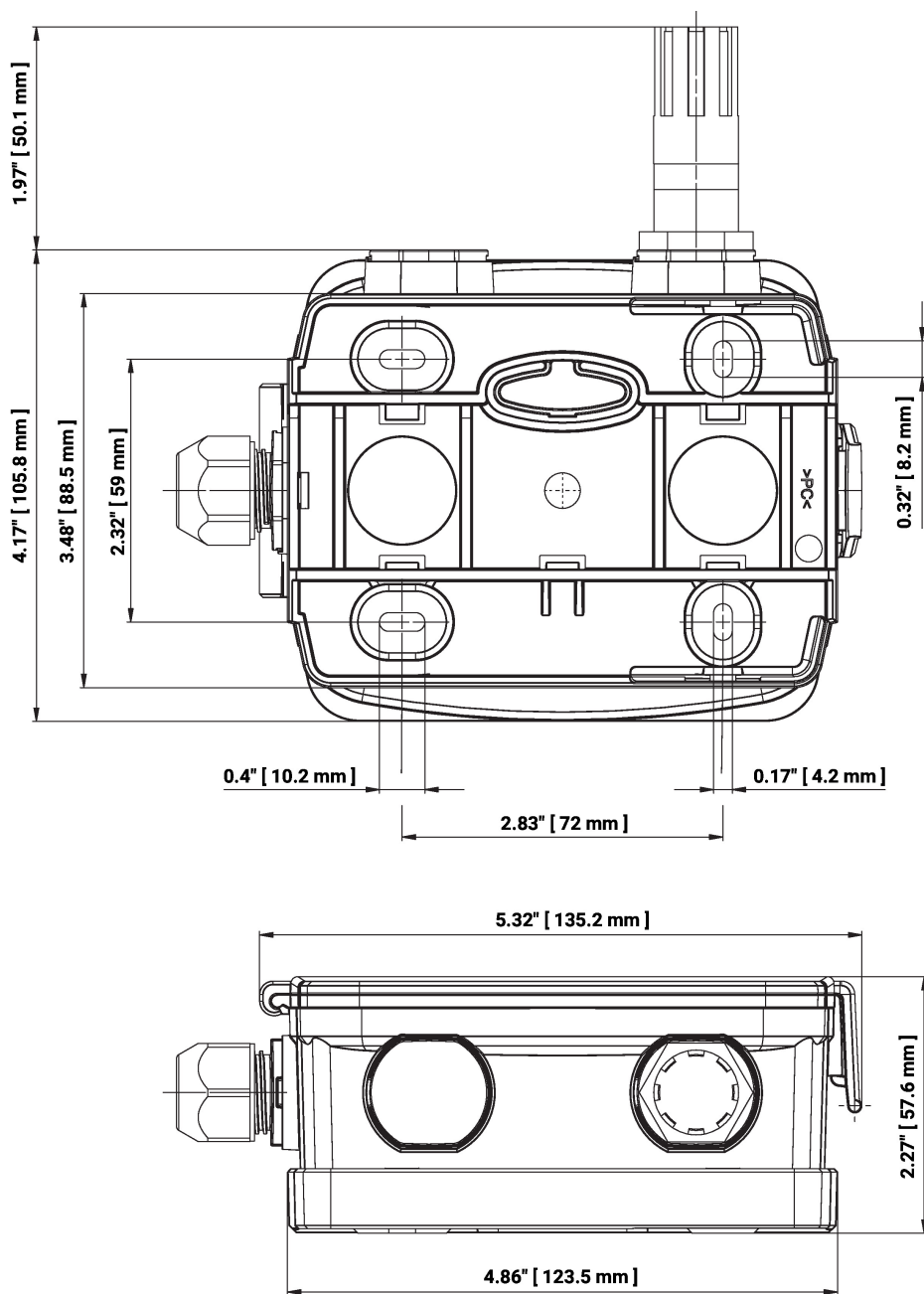

Further documentation

- Installation instructions
- Resistance characteristics